

# PORTICO M2: PDT-M2 Series

## Direct Thermal Portable Printer

### USER'S MANUAL

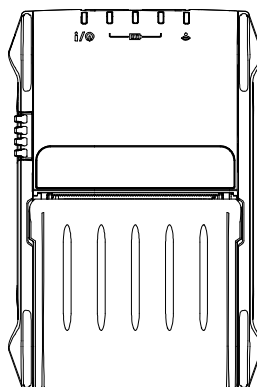

## **Copyright Information**

The copyright in this manual, the software and firmware in the printer described therein are owned by the company. All rights reserved.

CG Triumvirate is a trademark of Agfa Corporation. CG Triumvirate Bold Condensed font is under license from the Monotype Corporation. Windows is a registered trademark of Microsoft Corporation.

All other trademarks are the property of their respective owners.

Information in this document is subject to change without notice and does not represent a commitment on the part of the company. No part of this manual may be reproduced or transmitted in any form or by any means, for any purpose other than the purchaser's personal use, without the expressed written permission of the company.

## Agency Compliance and Approvals



2014/30/EU(EMC), 2014/35/EU(LVD), 2011/65/EU(RoHS 2.0)  
EN 55032 Class B  
EN 55024  
EN61000-3-2:2014  
EN61000-3-3:2013  
EN 60950-1



### FCC part 15B, Class B

This equipment has been tested and found to comply with the limits for a Class B digital device, pursuant to part 15 of the FCC Rules. These limits are designed to provide reasonable protection against harmful interference in a residential installation. This equipment generates, uses and can radiate radio frequency energy and, if not installed and used in accordance with the instructions, may cause harmful interference to radio communications. However, there is no guarantee that interference will not occur in a particular installation. If this equipment does cause harmful interference to radio or television reception, which can be determined by turning the equipment off and on, the user is encouraged to try to correct the interference by one or more of the following measures:

- Reorient or relocate the receiving antenna.
- Increase the separation between the equipment and receiver.
- Connect the equipment into an outlet on a circuit different from that to which the receiver is connected.
- Consult the dealer or an experienced radio/ TV technician for help.

This device complies with Part 15 of the FCC Rules. Operation is subject to the following two conditions: (1) This device may cause harmful interference, and (2) this device must accept any interference received, including interference that may cause undesired operation.

**This Class B digital apparatus complies with Canadian ICES-003**  
**Cet appareil numérique de la classe B est conforme à la norme NMB-003 du Canada.**



AS/NZS CISPR 22 Class B  
AS/NZS CISPR 32 Class B



EN 60950-1



NOM-019-SCFI-1998



10 C.F.R. Section 430.23(aa) (Appendix Y to Subpart B of part 430)



Energy Star for Imaging Equipment 2.0



TP TC 004/2011  
TP TC 020/2011

---



LP0002

---

Important safety instructions:

1. Read all of these instructions and keep them for later use.
2. Follow all warnings and instructions on the product.
3. Disconnect the power plug from the AC outlet before cleaning or if fault happened.
4. Do not use liquid or aerosol cleaners. Using a damp cloth is suitable for cleaning.
5. The mains socket shall be installed near the equipment and easily accessible.
6. The unit must be protected against moisture.
7. Ensure the stability when installing the device, Tipping or dropping could cause damage.
8. Make sure to follow the correct power rating and power type indicated on marking label provided by manufacture.
9. Please refer to user manual for maximum operation ambient temperature.

**WARNING:**

Hazardous moving parts, keep fingers and other body parts away.

**CAUTION:**

(For equipment with RTC (CR2032) battery or rechargeable battery pack)

Risk of explosion if battery is replaced by an incorrect type.

Dispose of used batteries according to the Instructions as below.

1. DO NOT throw the battery in fire.
2. DO NOT short circuit the contacts.
3. DO NOT disassemble the battery.
4. DO NOT throw the battery in municipal waste.
5. The symbol of the crossed out wheeled bin indicates that the battery should not be placed in municipal waste.



**Caution:** The printhead may be hot and could cause severe burns. Allow the printhead to cool.

**CAUTION:**

Any changes or modifications not expressly approved by the grantee of this device could void the user's authority to operate the equipment.

**CE Statement:**

This equipment complies with EU radiation exposure limits set forth for an uncontrolled environment. This equipment should be installed and operated with minimum distance 20 cm between the radiator & your body.

All operational modes:

2.4GHz: 802.11b, 802.11g, 802.11n (HT20), 802.11n (HT40), 5GHz: 802.11a

The frequency, mode and the maximum transmitted power in EU are listed below:

2400 MHz – 2483.5 MHz: 19.88 dBm (EIRP)

5150 MHz – 5250 MHz: 17.51 dBm (EIRP)

5150-5350MHz for Only indoor use

5470-5725MHz for indoor/outdoor use

**RF exposure warning (Wi-Fi)**

This equipment must be installed and operated in accordance with provided instructions and must not be co-located or operating in conjunction with any other antenna or transmitter. End-users and installers must be providing with antenna installation instructions and transmitter operating conditions for satisfying RF exposure compliance.

SAR Value: 0.736 W/kg

**RF exposure warning (For Bluetooth)**

The equipment complies with FCC RF exposure limits set forth for an uncontrolled environment. The equipment must not be co-located or operating in conjunction with any other antenna or transmitter.

**Canada, Industry Canada (IC) Notices**

This Class B digital apparatus complies with Canadian ICES-003 and RSS-210.

Operation is subject to the following two conditions: (1) this device may not cause interference, and (2) this device must accept any interference, including interference that may cause undesired operation of the device.

**Radio Frequency (RF) Exposure Information**

The radiated output power of the Wireless Device is below the Industry Canada (IC) radio frequency exposure limits. The Wireless Device should be used in such a manner such that the potential for human contact during normal operation is minimized.

This device has been evaluated for and shown compliant with the IC Specific Absorption Rate (“SAR”) limits when installed in specific host products operated in portable exposure conditions.

**(For Wi-Fi)**

This device has also been evaluated and shown compliant with the IC RF Exposure limits under portable exposure conditions. (Antennas are less than 20 cm of a person's body). **(For Bluetooth)**

## Canada, avis de l'Industry Canada (IC)

Cet appareil numérique de classe B est conforme aux normes canadiennes ICES-003 et RSS-210.

設備名稱：可攜式熱感條碼印表機，主型號：PORTICO M2 Series  
Equipment name: Portable Thermal Barcode Printer, Type designation (Type):

Son fonctionnement est soumis aux deux conditions suivantes : (1) cet appareil ne doit pas causer d'interférence et (2) cet appareil doit accepter toute interférence, notamment les interférences qui peuvent affecter son fonctionnement.

### Informations concernant l'exposition aux fréquences radio (RF)

La puissance de sortie émise par l'appareil sans fil est inférieure à la limite d'exposition aux fréquences radio de l'Industry Canada (IC). Utilisez l'appareil sans fil de façon à minimiser les contacts humains lors du fonctionnement normal.

Ce périphérique a été évalué et démontré conforme aux limites SAR (Specific Absorption Rate – Taux d'absorption spécifique) par l'IC lorsqu'il est connecté à des dispositifs hôtes spécifiques opérant dans des conditions d'utilisation mobile. **(Pour le Wi-Fi)**

Ce périphérique a également été évalué et démontré conforme aux limites d'exposition radio-fréquence par l'IC pour des utilisations par des opérateurs mobiles (les antennes sont à moins de 20 cm du corps d'une personne). **(Pour le Bluetooth)**

### NCC 警語:

經型式認證合格之低功率射頻電機，非經許可，公司、商號或使用者均不得擅自變更頻率、加大功率或變更原設計之特性及功能。(即低功率電波輻射性電機管理辦法第十二條)

低功率射頻電機之使用不得影響飛航安全及干擾合法通信；經發現有干擾現象時，應立即停用，並改善至無干擾時方得繼續使用。

前項合法通信，指依電信法規定作業之無線電通信。低功率射頻電機須忍受合法通信或工業、科學及醫療用電波輻射性電機設備之干擾。(即低功率電波輻射性電機管理辦法第十四條)

### 警告使用者：

此為甲類資訊技術設備，於居住環境中使用時，可能會造成射頻擾動，在此種情況下，使用者會被要求採取某些適當的對策。

單元 Unit	限用物質及其化學符號					
	鉛Lead (Pb)	汞Mercury (Hg)	鎘Cadmium (Cd)	六價鉻 Hexavalent chromium (Cr <sup>+6</sup> )	多溴聯苯 Polybrominated biphenyls (PBB)	多溴二苯醚 Polybrominated diphenyl ethers (PBDE)
內外塑膠件	○	○	○	○	○	○
內外鐵件	-	○	○	○	○	○
滾輪	○	○	○	○	○	○
電路板	-	○	○	○	○	○
晶片電阻	-	○	○	○	○	○
積層陶瓷表面 黏著電容	○	○	○	○	○	○
集成電路-IC	-	○	○	○	○	○
電源供應器	○	○	○	○	○	○
印字頭	○	○	○	○	○	○
插座	-	○	○	○	○	○
線材	-	○	○	○	○	○
<p>備考1: “超出0.1 wt %”及“超出0.01 wt %”係指限用物質之百分比含量超出百分比含量基準值。  Note 1: “Exceeding 0.1 wt %” and “exceeding 0.01 wt %” indicate that the percentage content of the restricted substance exceeds the reference percentage value of presence condition.</p> <p>備考2: “○”係指該項限用物質之百分比含量未超出百分比含量基準值。  Note 2: “○” indicates that the percentage content of the restricted substance does not exceed the percentage of reference value of presence.</p> <p>備考3: “-”係指該項限用物質為排除項目。  Note 3: The “-” indicates that the restricted substance corresponds to the exemption.</p>						

# Contents

<b>1. Introduction</b> .....	<b>1</b>
<b>1.1 Product Introduction</b> .....	<b>1</b>
<b>1.2 Product Features</b> .....	<b>2</b>
<b>1.2.1 Printer Standard Features</b> .....	<b>2</b>
<b>1.2.2 Printer Optional Features</b> .....	<b>3</b>
<b>1.3 General Specifications</b> .....	<b>5</b>
<b>1.4 Print Specifications</b> .....	<b>6</b>
<b>1.5 Media Specifications</b> .....	<b>6</b>
<b>2. Operations Overview</b> .....	<b>7</b>
<b>2.1 Unpacking and Inspection</b> .....	<b>7</b>
<b>2.2 Printer Overview</b> .....	<b>8</b>
<b>2.2.1 Front View</b> .....	<b>8</b>
<b>2.2.2 Interior View</b> .....	<b>9</b>
<b>2.2.3 Rear View</b> .....	<b>10</b>
<b>2.3 Operator control</b> .....	<b>11</b>
<b>2.3.1 LED Indication and Keys</b> .....	<b>11</b>
<b>3. Setup</b> .....	<b>12</b>
<b>3.1 Install the Battery</b> .....	<b>12</b>
<b>3.2 Charge the Battery</b> .....	<b>12</b>
<b>3.2.1 Charge the Battery</b> .....	<b>13</b>
<b>3.2.2 Charge by Charger Station (Optional)</b> .....	<b>14</b>
<b>3.3 Communicate</b> .....	<b>15</b>
<b>3.3.1 Connecting with the Communication Cable</b> .....	<b>15</b>
<b>3.3.2 Connecting with Bluetooth (Optional)</b> .....	<b>16</b>
<b>3.4 Loading the Media</b> .....	<b>17</b>
<b>4. Accessories</b> .....	<b>18</b>
<b>4.1 Install the Belt Clip</b> .....	<b>18</b>
<b>4.2 Install the IP54-rated environmental case with shoulder strap (Optional)</b> .....	<b>19</b>
<b>4.3 Install the media adapter (Optional)</b> .....	<b>20</b>
<b>5. Power-on Utilities</b> .....	<b>21</b>
<b>5.1 Media Sensor Calibration</b> .....	<b>21</b>
<b>5.2 Self-test and Dump Mode</b> .....	<b>22</b>
<b>5.3 Printer Initialization</b> .....	<b>25</b>
<b>6. Diagnostic Tool</b> .....	<b>26</b>
<b>6.1 Start the Diagnostic Tool</b> .....	<b>26</b>
<b>6.2 Printer Function</b> .....	<b>27</b>



**6.3 Calibrating Media Sensor by Diagnostic Tool .....28**  
**6.3.1 Auto Calibration .....28**  
**6.4 Setting Wi-Fi by Diagnostic Tool (Optional).....29**  
**6.5 Setting Bluetooth by Diagnostic Tool (Optional).....30**  
**7. Troubleshooting.....31**  
**7.1 Common Problems.....Error! Bookmark not defined.**  
**8. Maintenance .....32**  
**Revise History .....Error! Bookmark not defined.**

# 1. Introduction

## 1.1 Product Introduction

Thank you very much for purchasing PORTICO M2 bar code printer.

Enjoy our cost-efficient, high durability printers with the PORTICO M2 economical printer. The PORTICO M2 is a comfortable, light-weight printer capable of working with any mobile printing application where you need quick, simple receipts/labels on demand.

Our PORTICO M2 is designed for a rough life, inside the IP54-rated environmental case to resist dust and water and with its rubber over-mold design prepared to take up to a five-foot fall and keep printing.

These small and light printers can be worn comfortably for a full shift, without interfering with the user's tasks. Use USB or optional Bluetooth, 802.11 a/b/g/n Wireless or Serial to connect to a mobile computer or even a smartphone and produce clear easy-to-read receipts hour after hour.

This document provides an easy reference for operating the PORTICO M2.

The online version of the Programmer's manual, or more information can be downloaded from service and support website as an Adobe® Acrobat® Reader file.

To print label formats, please refer to the instructions provided with your labeling software; if you need to write the custom programs, please refer to the TSPL/TSPL2 programming manual that can be found on the accessories.

- Applications
  - Identification Wristbands
  - Direct store deliveries (DSD)
  - Proof of Delivery and Pickup
  - Field Sales/Repairs
  - Mobile Point-of-Sale
  - Parking Citations
  - Mobile Ticketing
  - Onboard Transportation Ticketing
  - Utility Billing/Meter Reading
  - Fleet Management

## 1.2 Product Features

### 1.2.1 Printer Standard Features

Product standard feature
Direct thermal printing (receipts & partial label)
Black mark reflective sensor
Head open sensor
3 operation buttons (On/off, feed/pause, and cover-open buttons)
5 LEDs: 1 for printer states (green or red); 3 for Battery capacity (green or orange); 1 for RF status (blue or green)
Audible alert Programmable buzzer
Mini type USB 2.0 (High speed mode)
64 MB DRAM
128 MB Flash memory
32-bit RISC high performance processor
Eltron® EPL, Epson® ESC-POS, and Zebra® ZPL emulation languages support
Fonts and bar codes can be printed in any one of the four directions (0, 90,180, 270 degree)
8 alpha-numeric bitmap fonts
One Monotype Imaging® CG Triumvirate Bold Condensed scalable font
Built-in Monotype True Type Font engine
Downloadable fonts from PC to printer memory
Downloadable firmware upgrades

Text, bar code, graphics/image printing (Please refer to the TSPL/TSPL2 programming manual for supporting code page)

Supported bar code		Supported image
1D bar code	2D bar code	
Code128 subsets A.B.C,Code128UCC, EAN128, Interleave 2 of 5,Code 39,Code 93, EAN-13, EAN-8, Codabar, POSTNET, UPC-A, UPC-E, EAN and UPC 2(5) digits add-on, MSI, PLESSEY, China Post, ITF14, EAN14, Code 11, TELPEN, PLANET, Code 49, Deutsche Post Identcode, Deutsche Post Leitcode, LOGMARS	CODABLOCK F mode, DataMatrix, Maxicode, PDF-417, Aztec, MicroPDF417, QR code, RSS Barcode (GS1 Databar)	BITMAP, BMP, PCX (Max. 256 colors graphics)

## 1.2.2 Printer Optional Features

The printer offers the following optional features.

Product option feature	User options	Factory options
Bluetooth V4.0 + EDR Standard mode ; support SMART READY		<input type="radio"/>
Wi-Fi 802.11 a/b/g/n		<input type="radio"/>
Bluetooth V4.2 + MFi ; support SMART READY		<input type="radio"/>
NFC tag		<input type="radio"/>
NFC (tag & reader)		<input type="radio"/>
TSPL-EZ, CPCL or ESC-POS emulation		<input type="radio"/>
128 MB DRAM memory		<input type="radio"/>
256 MB Flash memory		<input type="radio"/>

1 bay battery charger station	<input type="radio"/>	
4 bay batteries charger station	<input type="radio"/>	
Vehicle power adapter	<input type="radio"/>	
12-24V DC automobile cigarette lighter plug	<input type="radio"/>	
IP54-rated environmental case with shoulder strap	<input type="radio"/>	
Mini type USB cable	<input type="radio"/>	
Mini type USB to RS232 cable	<input type="radio"/>	
Li-ion battery	<input type="radio"/>	
Belt strap	<input type="radio"/>	
Fork truck mount	<input type="radio"/>	
Cart mount	<input type="radio"/>	
1 1/2" media adapter	<input type="radio"/>	
Linerless mode		<input type="radio"/>

## 1.3 General Specifications

General Specifications	
Physical dimensions	89.3 mm (W) 134.5 mm (H) x 56.5 mm (D)
Enclosure	Plastic
Weight (w/ battery)	350g
Electrical	<p>Internal charging capability (battery-in)</p> <ul style="list-style-type: none"> <li>■ 12VDC automobile cigarette lighter plug</li> <li>■ Auto-switching AC adapter</li> </ul> <p>External charging capability (battery-out)</p> <ul style="list-style-type: none"> <li>■ 1 bay battery charger station               <ul style="list-style-type: none"> <li>- Input: 100 ~ 240VAC</li> <li>- Output: 12 VDC, 1.5 A</li> </ul> </li> <li>■ 4 bay batteries charger station               <ul style="list-style-type: none"> <li>- Input: 100 ~ 240VAC</li> <li>- Output: 12 VDC, 1.5 A</li> </ul> </li> </ul> <p>Note: The printer will automatically turn off when stopping operation after 30 minutes.</p>
Environmental condition	<p>Operation Temperature: -20 ~ 50°C (-4 ~ 122°F)</p> <p>Charging Temperature: 0 ~ 40°C (32 ~ 104°F)</p> <p>Storage Temperature: -30 ~ 70 °C (-22 ~ 158°F)</p> <p>Relative Humidity:</p> <ul style="list-style-type: none"> <li>- Operation: 10% to 90% non-condensing</li> <li>- Storage: 10% to 90% non-condensing</li> </ul> <p>IP54 w/ protective case</p> <p>IP42 w/o protective case</p> <p>Drop 1.5m (5ft)</p> <p>Drop 2.0m (6.5ft) w/ IP54-rated environmental case with shoulder strap</p>

## 1.4 Print Specifications

Print Specifications	PORTICO M2
Print head resolution	203 dots/inch (8 dots/mm)
Printing method	Direct thermal (receipts & partial label)
Dot size	0.125 x 0.125 mm
(width x length)	(1 mm = 8 dots)
Print speed (inches per second)	Max. 4 ips (102 mm/sec) Max. 2 ips for linerless mode
Max. print width	48 mm (1.89")
Max. print length	Continuous receipt paper: 2,286 mm (90")
Printout bias	Vertical: 1 mm max.
	Horizontal: 1 mm max.

## 1.5 Media Specifications

Media Specifications	PORTICO M2
Media roll capacity	Label: 50 mm
Media type	Continuous, die-cut, receipt, and black mark
Media wound type	Outside wound
Media length	12.7 mm (0.5") ~ 2,286 mm (90") Tear mode: 50.8 mm (2.0") (suggested shortest printing length)
Media width	w/o adapter: 58 mm *w/ adapter: 50.8 mm and 25.4 mm ID core: 10.2 mm (0.4")
Media thickness	Receipt: 0.05 mm to 0.10 mm (2 mil to 4 mil) Label: Max. 0.14 mm (5.5 mil) Linerless: 2 mil ~ 3 mil (0.05 mm ~ 0.08 mm)

**Note:** Please locate the black mark on the printing side when using black mark continuous label.

## 2. Operations Overview

### 2.1 Unpacking and Inspection

This printer has been specially packaged to withstand damage during shipping. Please carefully inspect the packaging and printer upon receiving the bar code printer. Please retain the packaging materials in case you need to reship the printer.

Unpacking the printer, the following items are included in the carton.

- One printer unit
- One Li-ion battery
- One quick installation guide
- One Auto-switching AC adapter
- One belt clip
- USB Drive

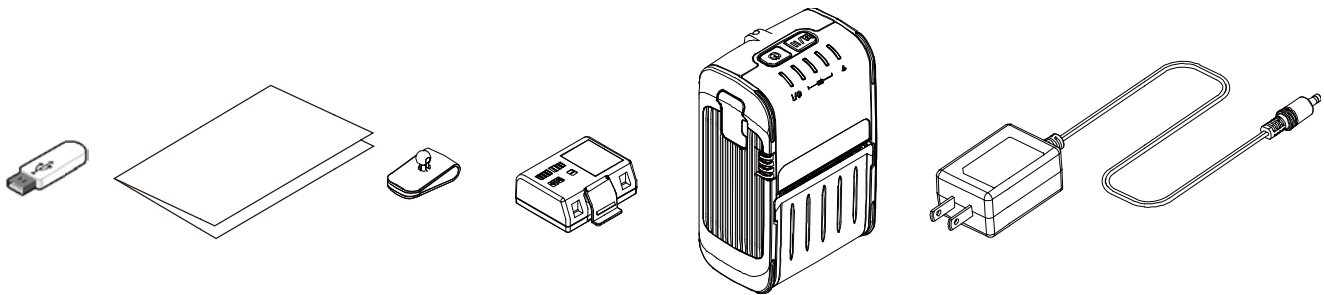

If any parts are missing, please contact the Customer Service Department of your purchased reseller or distributor.



# 2.2 Printer Overview

## 2.2.1 Front View

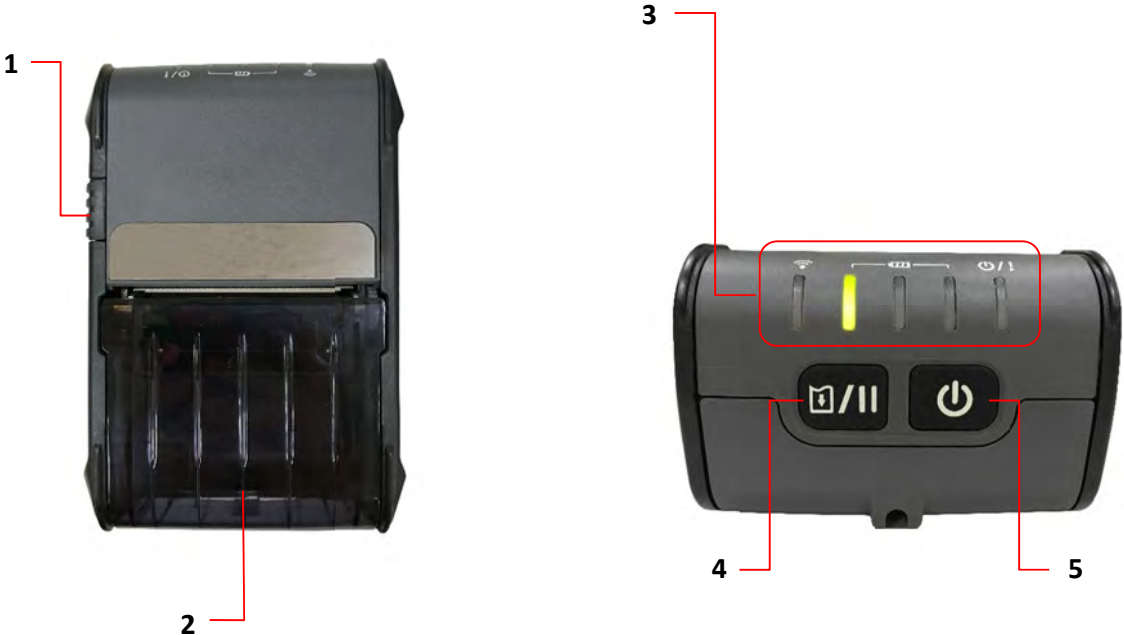

- 1. Media cover release button
- 2. Media cover
- 3. LED indicator
- 4. Feed/stop button
- 5. Power on/off button

### 2.2.2 Interior View

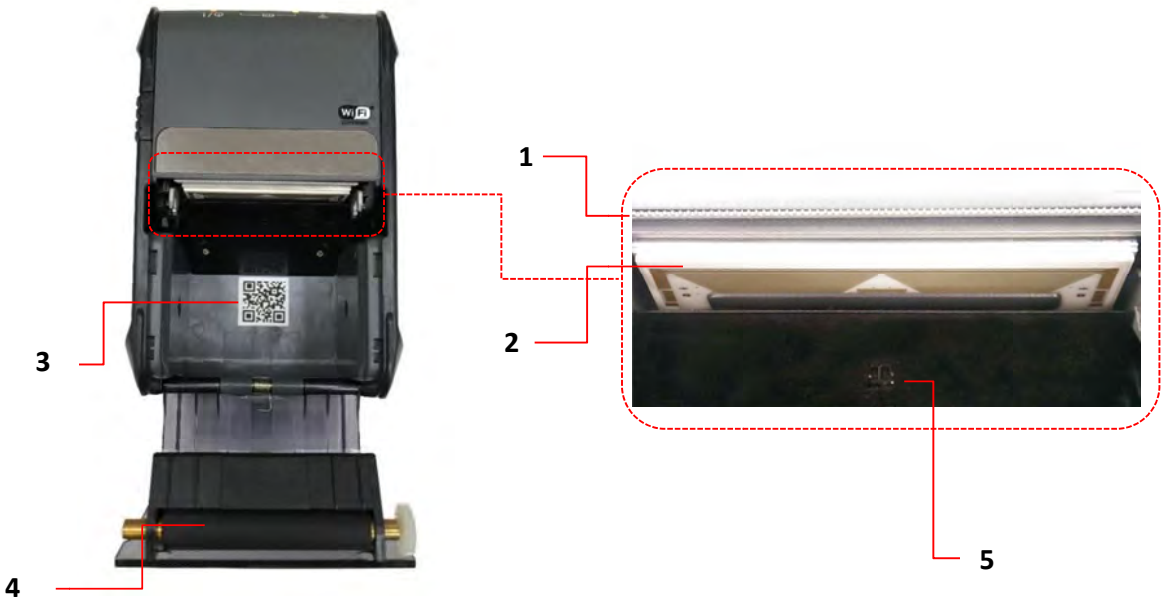

- 1. Tear edge
- 2. Print head
- 3. QR code label
- 4. Platen roller
- 5. Black mark sensor

### 2.2.3 Rear View





- 1. Li-ion Battery
- 2. Battery open clasp
- 3. USB interface
- 4. Power jack
- 5. Interface cover

## 2.3 Operator control

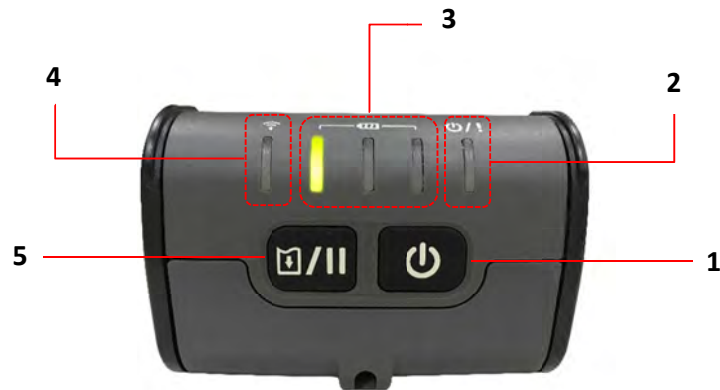
### 2.3.1 LED Indication and Keys



1. Power on/off button
2. Printer status LED indicator
3. Battery charge level LED indicator
4. Wireless status LED indicator
5. Feed/Pause button

Keys	Function
	<ol style="list-style-type: none"><li>1. Press and hold for 2-3 seconds to turn on the printer.</li><li>2. Press and hold for 2-3 seconds to turn off the printer.</li></ol>
	<ol style="list-style-type: none"><li>1. Ready status: Feed one label</li><li>2. Printing status: Pause the print job</li></ol>

## 3. Setup

### 3.1 Install the Battery

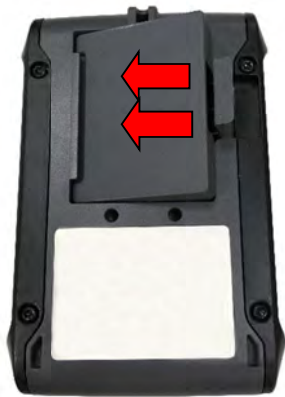

1. Insert the left side of battery to the slot on the rear of the printer.



2. Push the right side of the battery clasp down and lock the battery.

#### Battery safety warning:

**DO NOT** throw the battery in fire. **DO NOT** short circuit the contacts.

**DO NOT** disassemble the battery. **DO NOT** throw the battery in municipal waste.



The symbol of the crossed out wheeled bin (  ) indicates that the battery should not be placed in municipal waste.

### 3.2 Charge the Battery

It takes 1.5 to 2 hours to fully charge the battery before the first time usage. The lifetime of the battery is 300 times for charge/discharge cycles.

### 3.2.1 Charge the Battery



1. Open the interface cover and plug the power cord in to the power jack.

**Note:**

Please switch OFF printer power prior to plug in the power cord to printer power jack.

When the battery is charging, please do not remove the battery from the printer, otherwise, please re-plug the power cord into a power outlet.



2. Plug the power cord into a properly power outlet.

3. When the battery is charging, the color of battery status LED indicator is solid amber. The amber LED indicator will turned off after the battery is fully charged.



**Note:**

When checking the battery status, please connect the adapter and push power button, the LED indicator will turn to green then extinguished when the battery is fully charged.



### 3.2.2 Charge by Charger Station (Optional)



1. Plug the power cord to the power jack on the charger station.

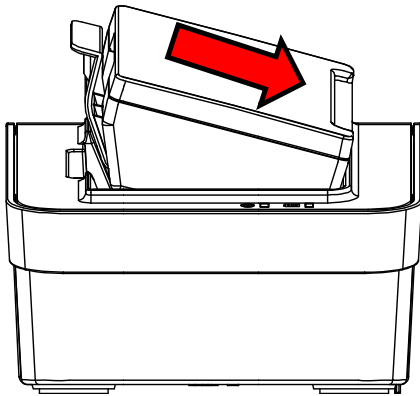

2. Insert the battery along the slot to the right side of charger station as pictured.

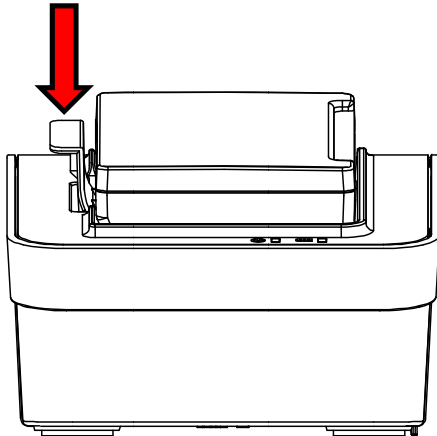

3. Push the battery clasp and properly install the battery, it will start charging.

**Note:**

The battery is completely charged and the amber of LED indicator will be off and turns to green.

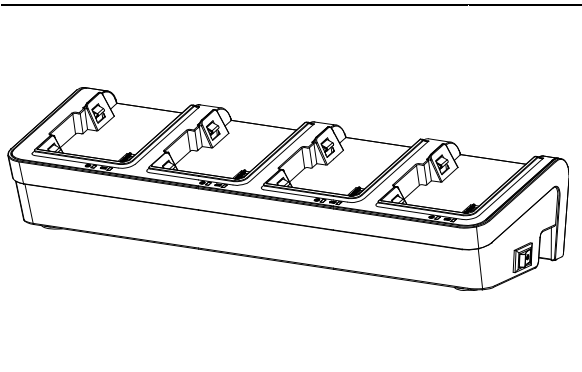

Note:  
The four bay batteries charger station is also available for your reference.

LED Color	Description
Green / Solid	Battery is completely charged
Red / Solid	Battery is charging
Red / Blinking	Battery charging error
Off	No battery
	Battery is completely charged over 1.5~2 hrs.

### 3.3 Communicate

#### 3.3.1 Connecting with the Communication Cable

- USB to USB Cable (Optional)



1. Open the interface cover and connect the printer to the computer with USB cable.



- USB to RS-232 Cable (Optional)

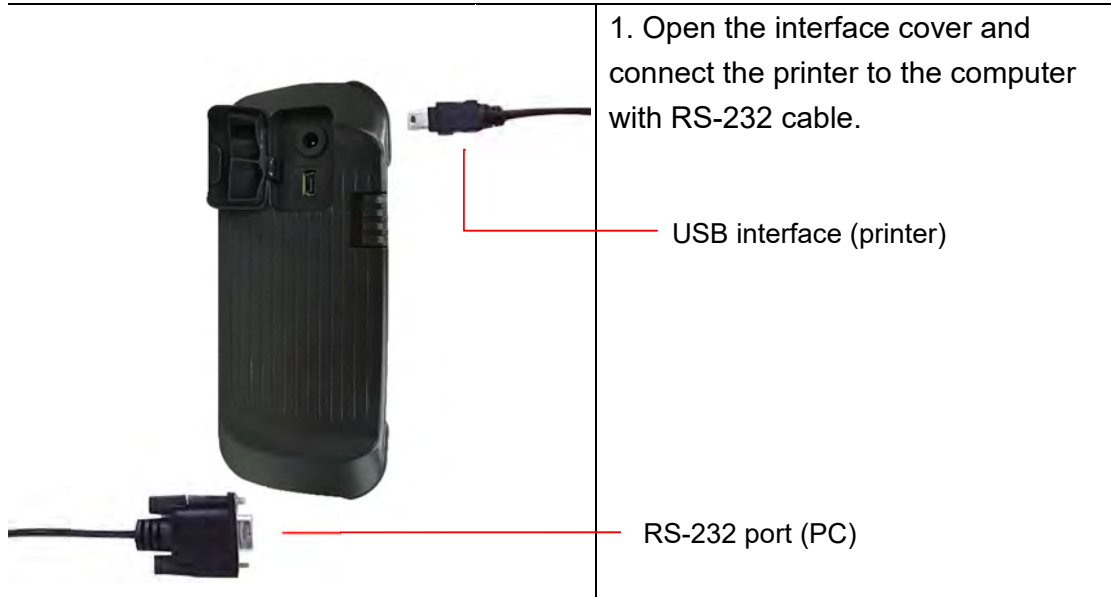

### 3.3.2 Connecting with Bluetooth (Optional)

Default	
Name	RF-BHS
PIN	0000

Turn on the printer and make sure the Bluetooth of device is opened.

**Note:**  
Please refer to section 6.5 to change the name of default and PIN.

### 3.4 Loading the Media



1. Open the printer media cover by pressing the media cover release button.



2. Place the media roll at the correct side, and pull out enough paper over the tear edge.

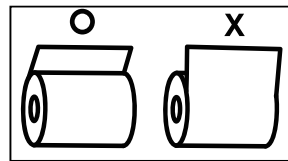

3. Press the media cover on both sides to close it and make sure the media cover have closed correctly.

## 4. Accessories

### 4.1 Install the Belt Clip



1. Remove the battery on the rear of the printer and lock the belt clip on the hole above the battery.



2. Press the ball on the belt clip to the hole as pictured.



3. After reinstalled the battery, the printer can be hung on the belt.

## 4.2 Install the IP54-rated environmental case with shoulder strap (Optional)

	<p>1. Open the case top cover.</p> <p>Top cover</p>
	<p>2. Place the printer in the case.</p> <p><b>Note:</b> The printing side must face the outside cover as indicated.</p>
<p>3. Close the case top cover. The outside cover should be opened and fixed while printing.</p>	
<p>Outside cover</p> 	<p>Outside cover fixed</p> 

### 4.3 Install the media adapter (Optional)



1. Open the printer top cover and install the media adapter in the media fixing hole as indicated.

Media fixing hole



2. The media adapters are installed in the media fixing hole on both sides.



2" media adapter

3. The media which installed in the adapter can prevent the poor print quality.

**Note:** Here are 1" and 2" media adapters available for your reference.









1" media adapter

## 5. Power-on Utilities

There are three power-on utilities to set up and test printer hardware. These utilities are activated by pressing FEED button () then turning on the printer power simultaneously and release the button at different positions of LED indicator.

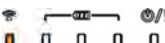

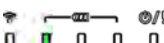
Please follow the steps below for different power-on utilities.

1. Turn off the printer power switch.
2. Hold on the FEED button () then turn on the power switch ()
3. Release the button () when LED indicates with different positions for different functions.

Power on utilities	The positions of LED light will be changed as following pattern:				
<b>LED</b>					
<b>Functions</b>	(Solid)	(5 blinks)	(5 blinks)	(5 blinks)	(Solid green)
<b>1. Media sensor calibration</b>		Release			
<b>2. Self-test and enter dump mode</b>			Release		
<b>3. Printer initialization</b>				Release	

### 5.1 Media Sensor Calibration

Please follow the steps below to calibrate the media sensor.

1. Turn off the power switch.
2. Hold on the FEED button () then turn on the power switch.
3. Release the FEED button () when the indicator becomes  and blinking. (Any green will do during the 5 blinks)

- It will calibrate the black mark sensor sensitivity.
- The LEDs will be changed as following order:

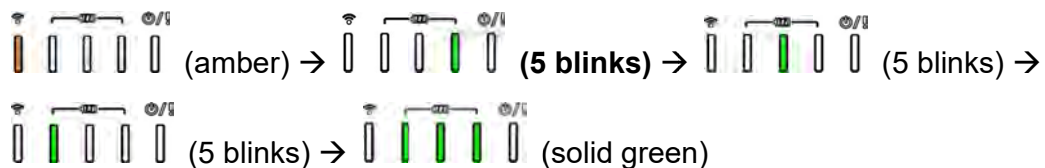

## 5.2 Self-test and Dump Mode

Please follow the steps below.

1. Turn off the power switch.
2. Hold on the FEED button (🖱️/🔑) then turn on the power switch.
3. Release the FEED button (🖱️/🔑) when the indicator becomes  and blinking. (Any green will do during the 5 blinks)

- The LEDs will be changed as following order:

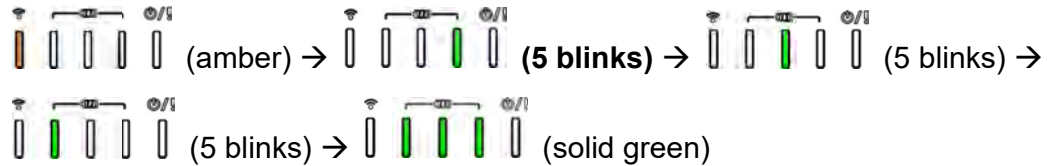

4. It calibrates the sensor and measures the media length and prints internal settings then enter the dump mode.
5. Turn off / on the power to resume printer for normal printing.

### ■ Self-test

Printer will print the printer configuration after media sensor calibration. Self-test printout can be used to check if there is any dot damage on the heater element, printer configurations and available memory space.

Self-test printout	
<pre> ----- SYSTEM INFORMATION ----- MODEL : XXXXXX FIRMWARE : X.XX CHECKSUM : XXXXXXXX S/N : XXXXXXXXXXXX TCF : NO DATE : 1970/01/01 TIME : 00:04:18 NON-RESET : 110      m (TPH) RESET : 110        m (TPH) NON-RESET : 0       (CUT) RESET : 0          (CUT) ----- </pre>	<p>Model name</p> <p>F/W version</p> <p>Firmware checksum</p> <p>Printer S/N</p> <p>Configuration file</p> <p>System date</p> <p>System time</p> <p>Printed mileage (meter)</p> <p>Cutting counter</p>

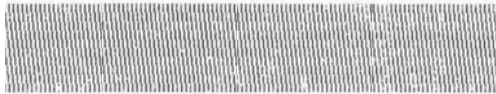
<pre> ----- PRINTING SETTING ----- SPEED: 5 IPS DENSITY: 8.0 WIDTH: 4.00 INCH HEIGHT: 4.00 INCH GAP: 0.00 INCH INTENSION: 5 CODEPAGE: 850 COUNTRY: 001 ----- </pre>	<ul style="list-style-type: none"> <li>Print speed (inch/sec)</li> <li>Print darkness</li> <li>Label size (inch)</li> <li>Gap distance (inch)</li> <li>Gap/black mark sensor intension</li> <li>Code page</li> <li>Country code</li> </ul>
<pre> ----- Z SETTING ----- DARKNESS: 16.0 SPEED: 4 IPS WIDTH: 4.00 INCH TILDE: 7EH (~)  CARET: 5EH (^) DELIMITER: 2CH (,) POWER UP: NO MOTION HEAD CLOSE: NO MOTION ----- </pre>	<p>ZPL setting information</p> <ul style="list-style-type: none"> <li>Print darkness</li> <li>Print speed (inch/sec)</li> <li>Label size</li> <li>Control prefix</li> <li>Format prefix</li> <li>Delimiter prefix</li> <li>Printer power up motion</li> <li>Printer head close motion</li> </ul> <p><b>Note:</b> ZPL is emulating for Zebra® language.</p>
<pre> ----- RS232 SETTING ----- BAUD: 9600 PARITY: NONE DATA BIT: 8 STOP BIT: 1 ----- </pre>	<p>RS232 serial port configuration</p>
<pre> ----- DRAM FILE (0 FILES) ----- PHYSICAL XXXX KBYTES AVAILABLE XXXX KBYTES -----  FLASH FILE (0 FILES) ----- PHYSICAL XXXX KBYTES AVAILABLE XXXX KBYTES -----   </pre>	<p>Numbers of download files Total &amp; available memory space</p> <p>Print head check pattern</p>



## ■ Dump mode

Printer will enter dump mode after printing printer configuration. In the dump mode, all characters will be printed in 2 columns as following. The left side characters are received from your system and right side data are the corresponding hexadecimal value of the characters. It allows users or engineers to verify and debug the program.

ASCII Data	→	<pre> SPEED 2,0 53 50 45 45 44 20 32 2E 30 0D DENSITY 8 0A 44 45 4E 53 49 54 59 20 38 SET PEEL 0D 0A 53 45 54 20 50 45 45 4C OFF DIRE 20 4F 46 46 0D 0A 44 49 52 45 CTION 0 0 43 54 49 4F 4E 20 30 0D 0A 47 AP 3,00 mm 41 50 20 33 2E 30 30 20 6D 6D ,0,00 mm 2C 30 2E 30 30 20 6D 6D 0D 0A REFERENCE 52 45 46 45 52 45 4E 43 45 20 0,0 SET C 30 2C 30 0D 0A 53 45 54 20 43 UTTER OFF 55 54 54 45 52 20 4F 46 46 0A SIZE 100, 0A 53 49 5A 45 20 31 30 30 2E 02 mm, 65,0 30 32 20 6D 6D 2C 36 35 2E 30 4 mm CLS 34 20 6D 6D 0D 0A 43 4C 53 0D BARCODE 1 0A 42 41 52 43 4F 44 45 20 31 44,149,"39 34 34 2C 31 34 39 2C 22 33 39 ,120,1,0, 22 2C 31 32 30 2C 31 2C 30 2C 2,0,"57114 32 2C 36 2C 22 35 37 31 31 34 38T," PRIN 33 38 54 22 0D 0A 50 52 49 4E T 1,1 SPE 54 20 31 2C 31 0D 0A 53 50 45 ED 2,0 DE 45 44 20 32 2E 30 0D 0A 44 45 NSITY 8 S 4E 53 49 54 59 20 38 0D 0A 53  ET PEEL OF 45 54 20 50 45 45 4C 20 4F 46 F DIRECTI 46 0D 0A 44 49 52 45 43 54 49 ON 0 GAP 4F 4E 20 30 0D 0A 47 41 50 20 3,00 mm,0, 33 2E 30 30 20 6D 6D 2C 30 2E 00 mm REF 30 30 20 6D 6D 0D 0A 52 45 46 ERENCE 0,0 45 52 45 4E 43 45 20 30 2C 30 SET CUTT 0D 0A 53 45 54 20 43 55 54 54 ER OFF SI 45 52 20 4F 46 46 0D 0A 53 49 ZE 100,02 5A 45 20 31 30 30 2E 30 32 20 mm,65,04 m 6D 6D 2C 36 35 2E 30 34 20 6D m CLS BA 6D 0D 0A 43 4C 53 0D 0A 42 41 RCODE 144, 52 43 4F 44 45 20 31 34 34 2C 149,"39",1 31 34 39 2C 22 33 39 22 2C 31 20,1,0,2,0 32 30 2C 31 2C 30 2C 32 2C 36 ,"5711438T 2C 22 35 37 31 31 34 35 38 54 ," PRINT 1 22 0D 0A 50 52 49 4E 54 20 31 ,1 2C 31 0D 0A </pre>	← Hex decimal data related to left column of ASCII data
------------	---	--	---

### Note:

1. Dump mode requires 2" wide paper width.
2. Turn off / on the power to resume printer for normal printing.

## 5.3 Printer Initialization

Printer initialization is used to clear DRAM and restore printer settings to defaults.

Printer initialization is activated by the following procedures.

1. Turn off the power switch.
2. Hold on the FEED button then turn on the power switch.
3. Release the FEED button when the indicator becomes  and blinking.  
(Any green will do during the 5 blinks).

- The LEDs will be changed as following order:

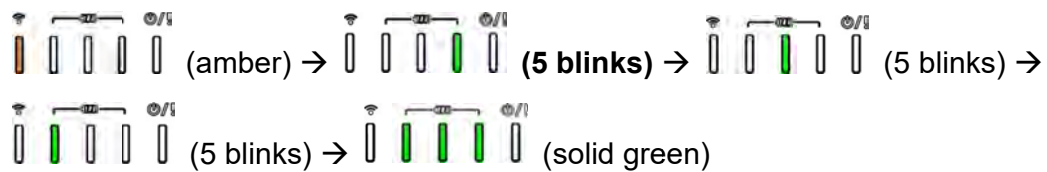



Printer configuration will be restored to defaults as below after initialization.

Parameter	Default setting
Speed	76.2 mm/sec (3 ips)
Density	8
Media Width	1.89" (48 mm)
Media Height	2" (50.8 mm)
Sensor Type	Black mark sensor (As paper end sensor)
Black Mark Setting	As paper end sensor
Print Direction	0
Reference Point	0,0 (upper left corner)
Offset	0
Serial Port Settings	9600 bps, none parity, 8 data bits, 1 stop bit
Code Page	850
Country Code	001
Clear Flash Memory	No
IP Address	DHCP

## 6. Diagnostic Tool

Diagnostic Utility is an integrated tool incorporating features that enable you to explore a printer's settings/status; change a printer's settings; download graphics, fonts and firmware; create a printer bitmap font; and send additional commands to a printer. With the aid of this powerful tool, you can review printer status and settings in an instant, which makes it much easier to troubleshoot problems and other issues.

### 6.1 Start the Diagnostic Tool

1. Double click on the Diagnostic tool icon   to start the software.
2. There are four features (Printer Configuration, File Manager, Bitmap Font Manager, Command Tool) included in the Diagnostic utility.

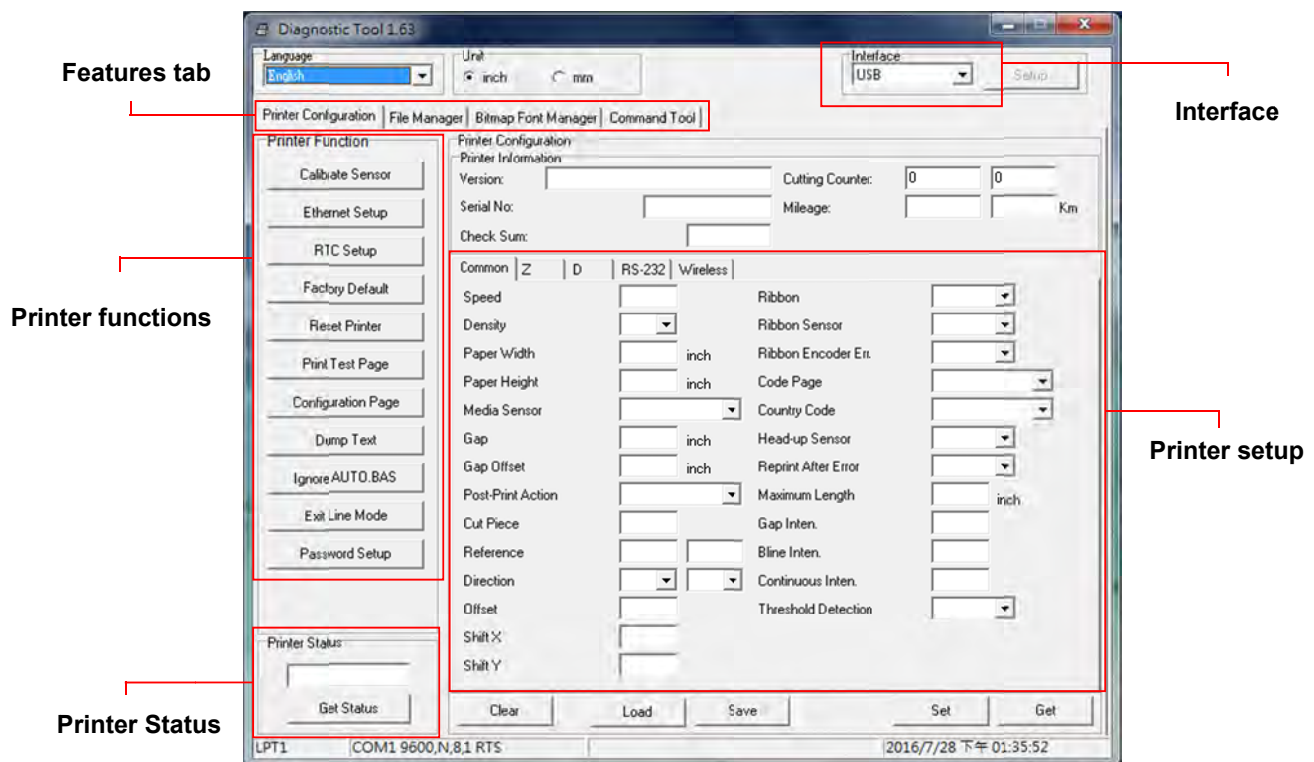

## 6.2 Printer Function

1. Select the PC interface connected with bar code printer.

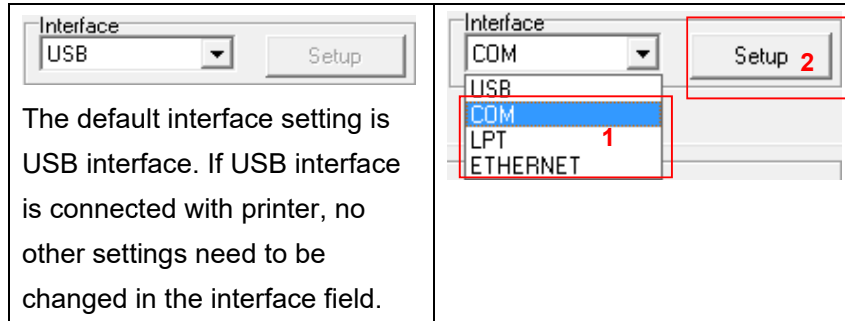

2. Click the “Printer Function” button to setup.
3. The detail functions in the Printer Function Group are listed as below.

Printer Function	Function	Description
Calibrate Sensor	Calibrate Sensor	Calibrate the sensor specified in the Printer Setup group media sensor field
Ethernet Setup	Ethernet Setup	Setup the IP address, subnet mask, gateway for the on board Ethernet
RTC Setup	RTC Setup	Synchronize printer Real Time Clock with PC
Factory Default	Factory Default	Initialize the printer and restore the settings to factory default. (Please refer section 5.3)
Reset Printer	Reset Printer	Reboot printer
Print Test Page	Print Test Page	Print a test page
Configuration Page	Configuration Page	Print printer configuration (Please refer section 5.2)
Dump Text	Dump Text	To activate the printer dump mode.
Ignore AUTO.BAS	Ignore AUTO.BAS	Ignore the downloaded AUTO.BAS program
Exit Line Mode	Exit Line Mode	Exit line mode.
Password Setup	Password Setup	Set the password to protect the settings

For more information about Diagnostic Tool, please refer to the diagnostic utility quick start guide on USB DRIVE (Utilities \ Diagnostic utility quick start guide).

**Note:** The three different print modes below are available, you can download the command on

Print modes	
DRAFT	High print speed with lower density.
OPTIMUM	According to the label content such as barcode, text, and graphic to lower the print speed for getting higher print quality.
STANDARD (default)	Standard print speed and quality.

## 6.3 Calibrating Media Sensor by Diagnostic Tool

### 6.3.1 Auto Calibration

1. Make sure the media is already installed and media cover is closed. (Please refer to section 3.4)
2. Turn on the printer power switch.
3. Open Diagnostic tool and set interface. (The default setting is USB)

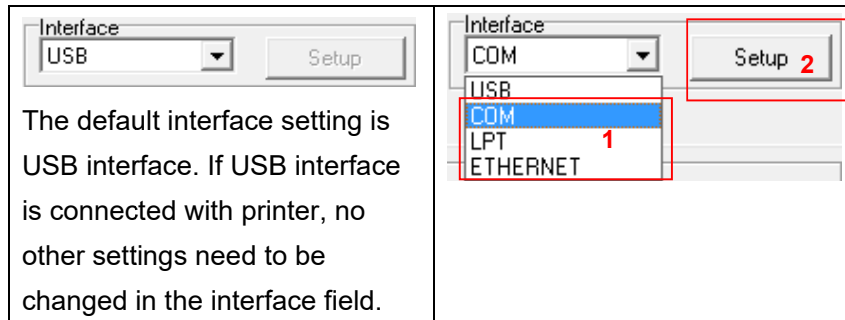

4. Click the “Calibrate Sensor” button.
5. Select the media type and click the “Calibrate” button.

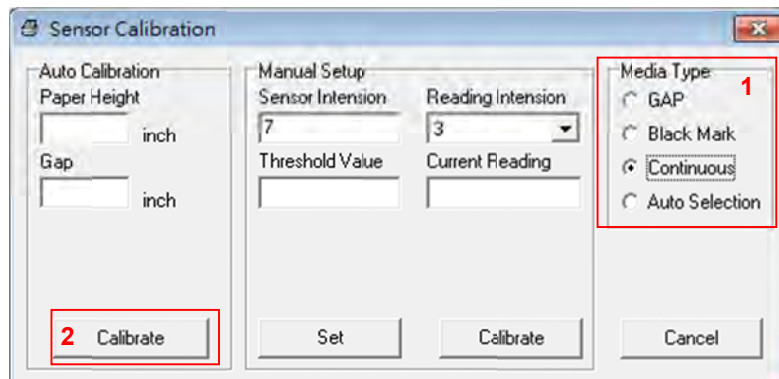

**Note:** The PORTICO M2 can only support continuous, die-cut, receipt, and black mark media type.

## 6.4 Setting Wi-Fi by Diagnostic Tool (Optional)

1. Make sure the media is already installed and media cover is closed. (Please refer to section 3.4)
2. Turn on the printer power switch.
3. Open Diagnostic tool and set interface. (The default setting is USB)

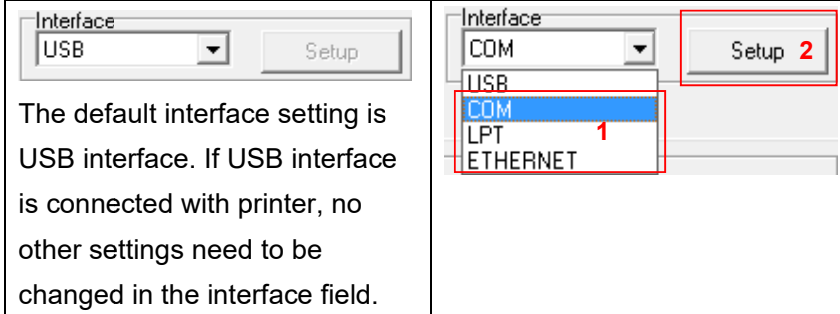

The default interface setting is USB interface. If USB interface is connected with printer, no other settings need to be changed in the interface field.

4. Select “Wireless” tab and “Built-in wireless module” item.
5. Enter and select the new WLAN settings in the editor.
6. Press “Set” button to set the new settings to the printer.
7. Press “Get” button to make sure WLAN is set properly.

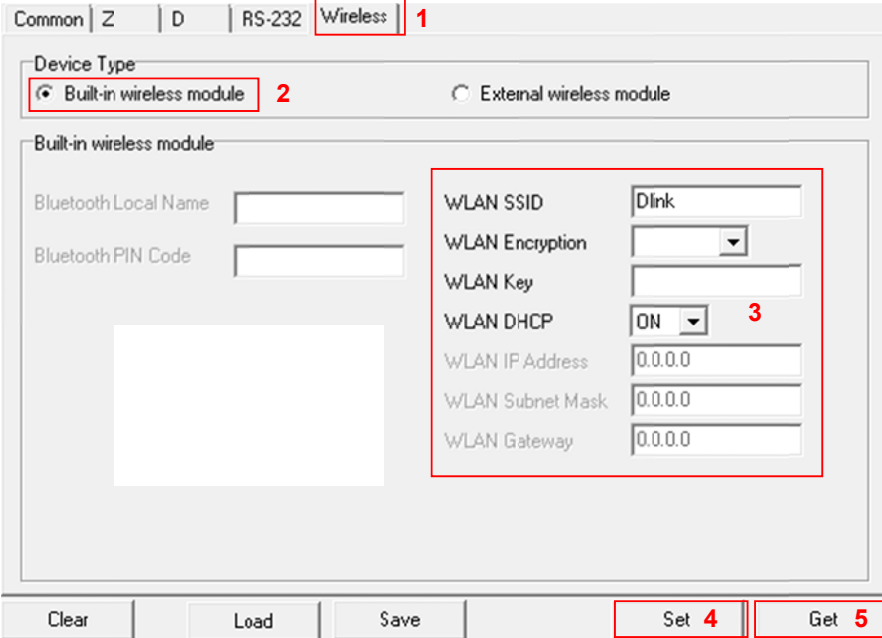

Common | Z | D | RS-232 | **Wireless** 1

Device Type  
 **Built-in wireless module** 2  External wireless module

Built-in wireless module

Bluetooth Local Name

Bluetooth PIN Code

WLAN SSID

WLAN Encryption

WLAN Key

WLAN DHCP  3

WLAN IP Address

WLAN Subnet Mask

WLAN Gateway

Clear Load Save **Set** 4 **Get** 5

**Note:**

\* The printer connects with the computer via USB cable or RS-232 cable, which are option.

## 6.5 Setting Bluetooth by Diagnostic Tool (Optional)

1. Make sure the media is already installed and media cover is closed. (Please refer to section 3.4)
2. Turn on the printer power switch.
3. Open Diagnostic tool and set interface. (The default setting is USB)

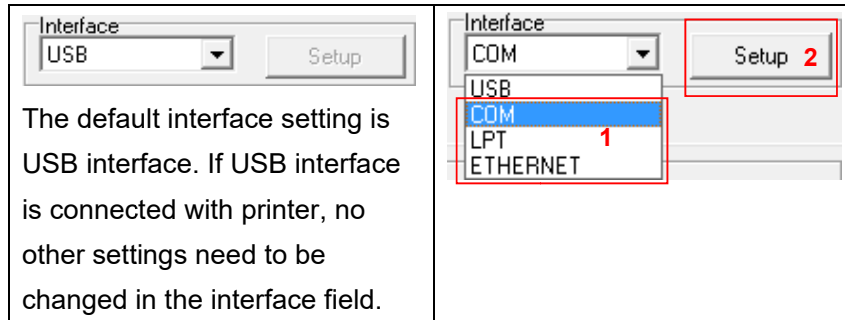

4. Select “Wireless” tab and “Built-in wireless module” item.
5. Enter the new BT Local Name or BT PIN Code in the editor.
6. Press “Set” button to set the new BT name or BT PIN code of the printer.
7. Press “Get” button to get back the settings. Make sure the Bluetooth module settings are set properly.

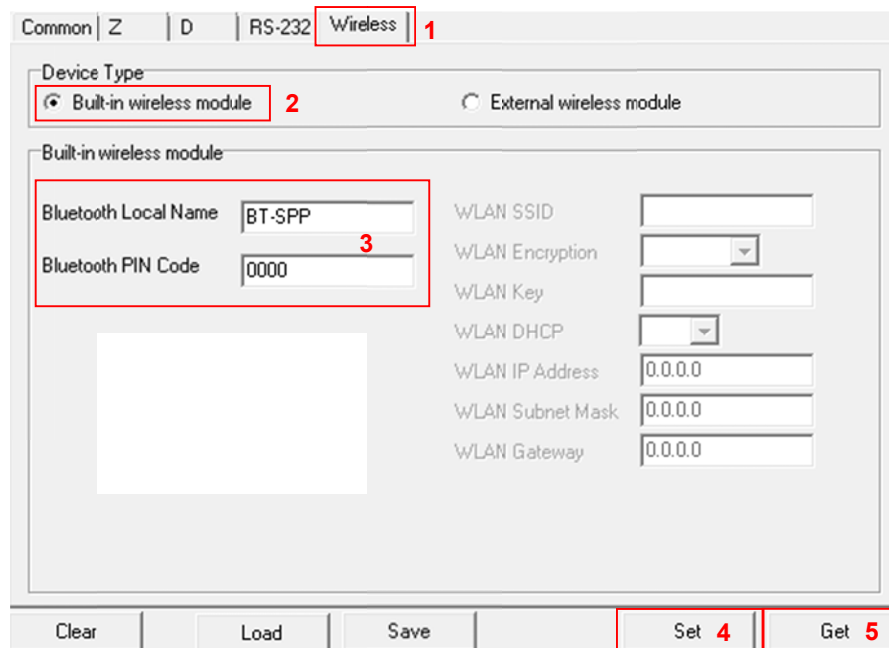

**Note:**

\* The printer connects with the computer via USB cable or RS-232 cable, which are option.

## 7. Troubleshooting Common Problems

The following guide lists the most common problems that may be encountered when operating this bar code printer. If the printer still does not function after all suggested solutions have been invoked, please contact the Customer Service Department for assistance.

<b>Problem</b>	<b>Possible Cause</b>	<b>Recovery Procedure</b>
<b>Power indicator does not illuminate</b>	<ul style="list-style-type: none"> <li>* The battery is not properly installed.</li> <li>* The battery is dead.</li> </ul>	<ul style="list-style-type: none"> <li>* Reinstall the battery.</li> <li>* Switch the printer on.</li> <li>* Charge the battery.</li> </ul>
- The printer status from DiagTool shows " <b>Head Open</b> ".	<ul style="list-style-type: none"> <li>* The printer carriage is open.</li> </ul>	<ul style="list-style-type: none"> <li>* Please close the print carriage.</li> </ul>
- The printer status from DiagTool shows " <b>Out of Paper</b> ".	<ul style="list-style-type: none"> <li>* Running out of media roll.</li> <li>* The media is installed incorrectly.</li> <li>* Black mark sensor is not calibrated.</li> </ul>	<ul style="list-style-type: none"> <li>* Place a new media roll.</li> <li>* Please refer to the steps on section 3.4 to reinstall the media roll.</li> <li>* Calibrate the black mark sensor.</li> </ul>
- The printer status from DiagTool shows " <b>Paper Jam</b> ".	<ul style="list-style-type: none"> <li>* Black mark sensor is not set properly.</li> <li>* Make sure media size is set properly.</li> <li>* Media may be stuck inside the printer mechanism.</li> </ul>	<ul style="list-style-type: none"> <li>* Calibrate the black mark sensor.</li> <li>* Set media size correctly.</li> </ul>
<b>Memory full ( FLASH / DRAM )</b>	<ul style="list-style-type: none"> <li>* The space of FLASH/DRAM is full.</li> </ul>	<ul style="list-style-type: none"> <li>* Delete unused files in the FLASH/DRAM.</li> <li>* Run printer self-test and check the available memory space for DRAM or FLASH.</li> <li>* Check the available memory space for DRAM or FLASH via DiagTool.</li> </ul>
<b>Poor Print Quality</b>	<ul style="list-style-type: none"> <li>* Media is loaded incorrectly</li> <li>* Dust or adhesive accumulation on the print head.</li> <li>* Print density is not set properly.</li> <li>* Print head element is damaged.</li> </ul>	<ul style="list-style-type: none"> <li>* Reload the media.</li> <li>* Clean the print head.</li> <li>* Clean the platen roller.</li> <li>* Adjust the print density and print speed.</li> <li>* Run printer self-test and check the print head test pattern if there is dot missing in the pattern.</li> <li>* Change proper media roll.</li> </ul>
<b>Missing printing on the left or right side of label</b>	<ul style="list-style-type: none"> <li>* Wrong label size setup.</li> </ul>	<ul style="list-style-type: none"> <li>* Set the correct label size.</li> </ul>
<b>Gray line on the blank label</b>	<ul style="list-style-type: none"> <li>* The print head is dirty.</li> <li>* The platen roller is dirty.</li> </ul>	<ul style="list-style-type: none"> <li>* Clean the print head.</li> <li>* Clean the platen roller.</li> </ul>
<b>Irregular printing</b>	<ul style="list-style-type: none"> <li>* The printer is in Hex Dump mode.</li> <li>* The RS-232 setting is incorrect.</li> </ul>	<ul style="list-style-type: none"> <li>* Turn off and on the printer to skip the dump mode.</li> <li>* Re-set the Rs-232 setting.</li> </ul>



## 8. Maintenance

This session presents the clean tools and methods to maintain your printer.

1. Please use one of following material to clean the printer.

- Cotton swab
- Lint-free cloth
- Vacuum / Blower brush
- 100% Ethanol or Isopropyl Alcohol

2. The cleaning process is described as following,

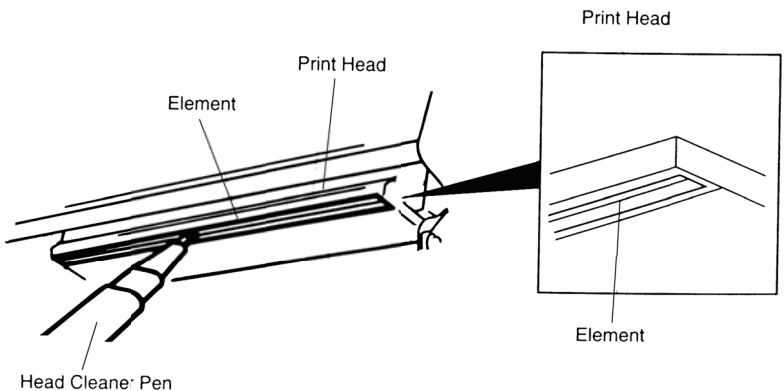
Printer Part	Method	Interval
<b>Print Head</b>	1. Always turn off the printer before cleaning the print head. 2. Allow the print head to cool for a minimum of one minute. 3. Use a cotton swab and 100% Ethanol or Isopropyl Alcohol to clean the print head surface.	Clean the print head when changing media (label)
		
<b>Platen Roller</b>	1. Turn the power off. 2. Rotate the platen roller and wipe it thoroughly with water.	Clean the platen roller when changing media (label)
<b>Tear Bar/Peel Bar</b>	Use the lint-free cloth with 100% ethanol to wipe it.	As needed
<b>Sensor</b>	Compressed air or vacuum	Monthly
<b>Exterior</b>	Wipe it with water-dampened cloth	As needed
<b>Interior</b>	Brush or vacuum	As needed

**Note:**

- Do not touch printer head by hand. Please use ethanol to clean it.
- Please use 100% Ethanol or Isopropyl Alcohol. DO NOT use medical alcohol, which may damage the printer head.
- Regularly clean the print head and media sensors to keep printer performance and extend printer life.

